



N° 0296, 0296SI

The Building Test Centre
British Gypsum Limited
East Leake, Loughborough
Leicestershire, LE12 6NP
Tel. 0115 945 1564
Fax. 01509 856780



Report Number BTC 3056A

ACOUSTIC TEST REPORT COVERING
LABORATORY SOUND ABSORPTION TEST TO
BS EN 20354: 1993 ON 12.5mm GYPROC BIG
QUATTRO 8B CEILING TILES ABOVE A 187mm
AIRSPACE.

Test Date: 12th June 1996

Customer:

Gyproc AB.
Box 505
S-201 265
Malmo
Sweden



The Building Test Centre
 British Gypsum Limited
 East Leake, Loughborough
 Leicestershire, LE12 6NP
 Tel. 0115 945 1564
 Fax. 01509 856780



N° 0296, 0296SI

ACOUSTIC TEST REPORT COVERING LABORATORY SOUND ABSORPTION TEST TO BS EN 20354: 1993 ON 12.5mm GYPROC BIG QUATTRO 8B CEILING TILES ABOVE A 187mm AIRSPACE.

DESCRIPTION

12.5mm Gyproc BIG Quattro 8B ceiling tiles manufactured by Gyproc AB, Sweden, with full depth square holes over the surface. Adhered to the back of the board was a porous tissue. The ceiling tiles were placed over a 187mm airspace over the concrete floor of the reverberation chamber. The specimen test frame was constructed from high density chipboard with 45mm x 45mm timber battens located at 1200mm centres running across in one direction. The frame was sealed to the chamber floor with Gyproc sealant. The perimeter edges of the boards were sealed using Gyproc adhesive tape.

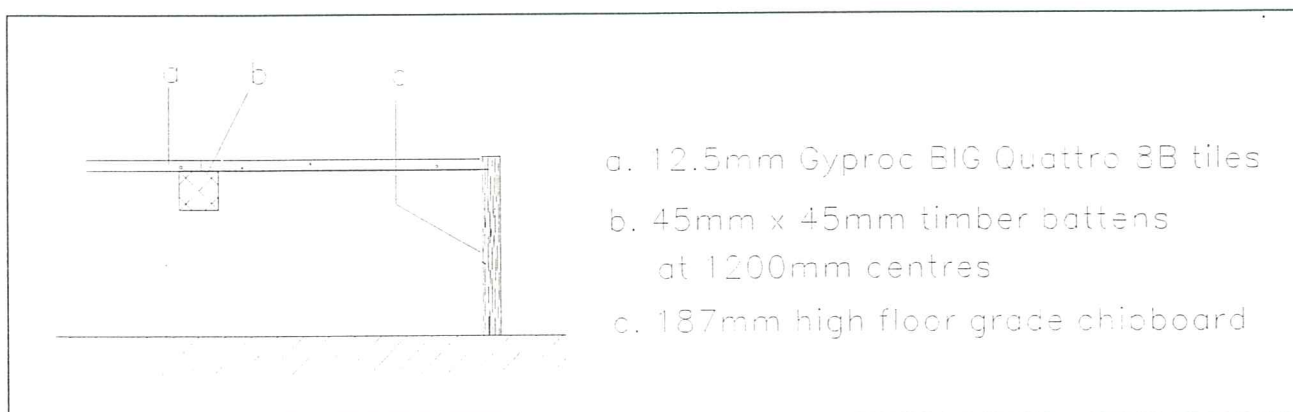

Figure 1: Section through test sample

The descriptions of individual components making up the test specimen were provided by the customer and were checked for accuracy wherever possible.

RESULT

For full test results see tabulated data on page 4.

Test conducted in accordance with BS EN 20354:1993 and ISO 354:1985.
 NRC calculated in accordance with ASTM C423-90a 1992.



The Building Test Centre
British Gypsum Limited
East Leake, Loughborough
Leicestershire, LE12 6NP
Tel. 0115 945 1564
Fax. 01509 856780



N° 0296, 0296SI

MATERIALS

Gyproc BIG Quattro 8B ceiling tiles

Nominally 12.5mm (thick) x 1200 (wide) x 2400mm (long) Gyproc BIG Quattro ceiling tiles manufactured by Gyproc AB.

| | |
|------------------------------|------------------------|
| Actual surface density: | 8.02 kg/m ² |
| Actual thickness: | 12.66 mm |
| Board identification number: | - |
| Nominal moisture content: | - |

Surface density calculated using actual weight of boards used in the test specimen.

TEST PROCEDURE

For each of three microphone locations and the two loudspeaker positions, 2 decays are taken for each combination, making a total of 12 decays. The two loudspeaker positions are placed in diagonally opposite corners of the room - one on the floor and one in the upper corner. Broad-band pink noise and third-octave band filters in real time mode are used to make simultaneous measurements for all frequency bands. The test procedure used was 20354 issue 1. See appendix for further information.

Report Author:

Arshad Mahmood BSc
Senior Technologist

Head of Laboratory:

Paul Royle B.Tech.(Hons.), M.Sc., MIOA
Executive Manager

Report Date: 1 July 1996



The Building Test Centre
 British Gypsum Limited
 East Leake, Loughborough
 Leicestershire, LE12 6NP
 Tel. 0115 945 1564
 Fax. 01509 856780



N° 0296, 0296SI

SOUND ABSORPTION TEST

TEST CODE R3056A Test Date 12-06-96

Sample: Gyproc BIG Quattro 3B tiles on 187mm timber frame with battens

EMPTY ROOM : Air. Temp. = 19.4 C : Rel. Hum. = 50.8 %
 WITH SAMPLE: Air. Temp. = 19.5 C : Rel. Hum. = 51.5 %

SAMPLE AREA = 10.8 M²

| FREQ Hz | T20* empty | T20* sample | ABS COEFF as | ASTM values |
|------------|---------------|----------------|-----------------|----------------|
| 50 | 24.26 | 8.76 | 0.21 | |
| 63 | 21.84 | 7.49 | 0.26 | |
| 80 | 15.55 | 5.77 | 0.32 | |
| 100 | 13.35 | 4.22 | 0.47 | |
| 125 | 11.65 | 4.32 | 0.43 | 0.43 |
| 160 | 8.64 | 3.43 | 0.51 | |
| 200 | 10.50 | 3.37 | 0.59 | |
| 250 | 12.13 | 3.40 | 0.62 | 0.32 |
| 315 | 11.49 | 3.38 | 0.61 | |
| 400 | 9.03 | 3.22 | 0.58 | |
| 500 | 7.11 | 2.98 | 0.60 | 0.60 |
| 630 | 7.35 | 3.19 | 0.54 | |
| 800 | 7.76 | 3.35 | 0.60 | |
| 1000 | 7.90 | 3.45 | 0.43 | 0.43 |
| 1250 | 7.35 | 3.51 | 0.44 | |
| 1600 | 6.37 | 3.24 | 0.44 | |
| 2000 | 5.64 | 3.13 | 0.42 | 0.42 |
| 2500 | 4.99 | 2.98 | 0.40 | |
| 3150 | 3.90 | 2.54 | 0.40 | |
| 4000 | 3.02 | 2.13 | 0.40 | 0.40 |
| 5000 | 2.41 | 1.85 | 0.37 | |

* Average of 12 decays

NRC (ASTM C423-90a) = .55

Tested by A. Wood Checked by [Signature]

Test Standard :- BS EN 20354:1993

Test Procedure :- 20354 issue 1

Program Name :- REV4B

Plot Program :- ABSPLOT2

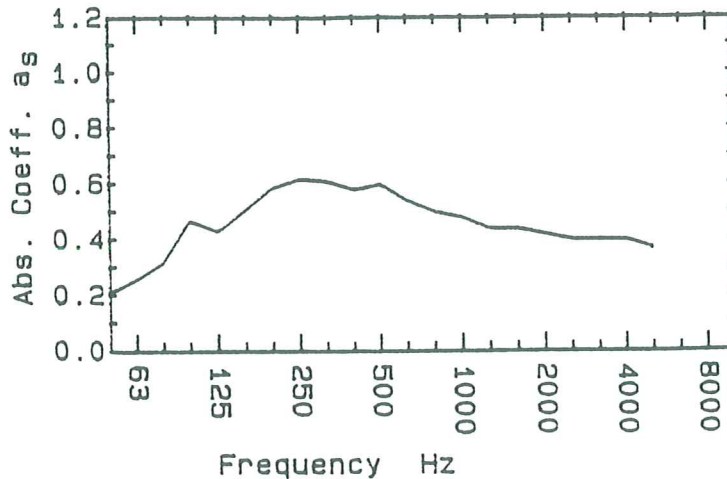



The Building Test Centre
 British Gypsum Limited
 East Leake, Loughborough
 Leicestershire, LE12 6NP
 Tel. 0115 945 1564
 Fax. 01509 856780



N° 0296, 0296SI

TEST METHOD AND CONDITIONS

The test room with a volume of 196m³ is treated with 16 perspex diffusers of approximately 1220mm x 1220mm dimensions positioned randomly throughout the room.

The test specimen is of rectangular shape with an area between 10 and 12 m² placed in the test room so that no part of it is closer than 1m to any edge of the boundary of the room. The edges of the test specimen are tightly enclosed by a reflective frame, sealed to the floor and protruding above the surface of the test specimen.

The equivalent sound absorption area is determined by the measured reverberation times and used to calculate the absorption coefficients.

The repeatability of measurement for low absorption, r_1 , and high absorption, r_2 , are

| Freq Hz | 100 | 125 | 160 | 200 | 250 | 315 | 400 | 500 | 630 | 800 | 1000 | 1250 | 1600 | 2000 | 2500 | 3150 |
|------------|------|------|------|------|------|------|------|------|------|------|------|------|------|------|------|------|
| r_1 | .035 | .064 | .018 | .018 | .035 | 0 | .018 | 0 | .035 | .028 | .028 | .021 | .053 | .066 | .033 | .048 |
| r_2 | .056 | .077 | .085 | .068 | .146 | .106 | .213 | .205 | .2 | .116 | .051 | .218 | .109 | .068 | .048 | .06 |

The figure below shows the section and floor plan view of the test room.

