



N° 0296, 0296SI

The Building Test Centre  
British Gypsum Limited  
East Leake, Loughborough  
Leicestershire, LE12 6NP  
Tel. 0115 945 1564  
Fax. 01509 856780



## Report Number BTC 3057A

ACOUSTIC TEST REPORT COVERING  
LABORATORY SOUND ABSORPTION TEST TO  
BS EN 20354: 1993 ON 12.5mm GYPROC BIG  
QUATTRO 72B CEILING TILES ABOVE A 187mm  
AIRSPACE.

Test Date: 12th June 1996

Customer:

**Gyproc AB.**

Box 505  
S-201 265  
Malmo  
Sweden

**ACOUSTIC TEST REPORT COVERING LABORATORY SOUND ABSORPTION TEST TO  
BS EN 20354: 1993 ON 12.5mm GYPROC BIG QUATTRO 72B CEILING TILES ABOVE A  
187mm AIRSPACE.**

**DESCRIPTION**

12.5mm Gyproc BIG Quattro 72B ceiling tiles manufactured by Gyproc AB, Sweden, with full depth square holes over the surface. Adhered to the back of the board was a porous tissue. The open area of the holes was 5.8% of the total face area. The ceiling tiles were placed over a 187mm airspace over the concrete floor of the reverberation chamber. The specimen test frame was constructed from high density chipboard with 45mm x 45mm timber battens located at 1200mm centres running across in one direction. The frame was sealed to the chamber floor with Gyproc sealant. The perimeter edges of the boards were sealed using Gyproc adhesive tape.

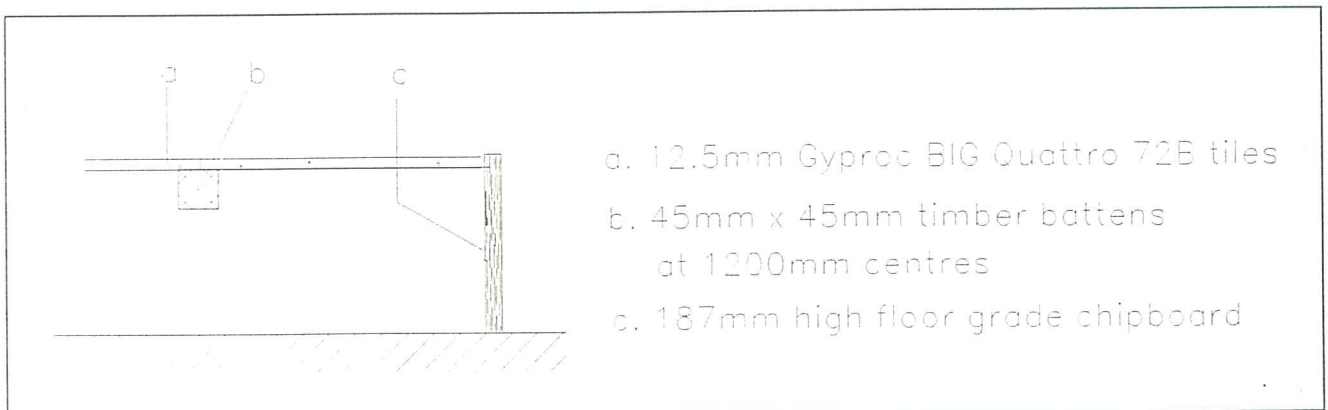

Figure 1: Section through test sample

*The descriptions of individual components making up the test specimen were provided by the customer and were checked for accuracy wherever possible.*

**RESULT**

For full test results see tabulated data on page 4.

Test conducted in accordance with BS EN 20354:1993 and ISO 354:1985.  
NRC calculated in accordance with ASTM C423-90a 1992.



N° 0296, 0296SI

**The Building Test Centre**  
British Gypsum Limited  
East Leake, Loughborough  
Leicestershire, LE12 6NP  
Tel. 0115 945 1564  
Fax. 01509 856780



## MATERIALS

### Gyproc BIG Quattro 72B ceiling tiles

Nominally 12.5mm (thick) x 1200 (wide) x 2400mm (long) Gyproc BIG Quattro ceiling tiles manufactured by Gyproc AB.

Actual surface density:	8.38 kg/m <sup>2</sup>
Actual thickness:	12.62 mm
Board identification number:	-
Nominal moisture content:	-

Surface density calculated using actual weight of boards used in the test specimen.

## TEST PROCEDURE

For each of three microphone locations and the two loudspeaker positions, 2 decays are taken for each combination, making a total of 12 decays. The two loudspeaker positions are placed in diagonally opposite corners of the room - one on the floor and one in the upper corner. Broad-band pink noise and third-octave band filters in real time mode are used to make simultaneous measurements for all frequency bands. The test procedure used was 20354 issue 1. See appendix for further information.

Report Author:

**Arshad Mahmood BSc**  
*Senior Technologist*

Head of Laboratory:

**Paul Royle B.Tech.(Hons.), M.Sc., MIOA**  
*Executive Manager*

Report Date: 1 July 1996



The Building Test Centre  
 British Gypsum Limited  
 East Leake, Loughborough  
 Leicestershire, LE12 6NP  
 Tel. 0115 945 1564  
 Fax. 01509 856780



N° 0296, 0296SI

SOUND ABSORPTION TEST

TEST CODE R3057A Test Date 12-06-96

Sample: Gyproc BIG Quattro 72B tiles on 187mm timber frame with battens.

EMPTY ROOM : Air. Temp. = 19.4 C : Rel. Hum. = 50.3 %  
 WITH SAMPLE: Air. Temp. = 19.4 C : Rel. Hum. = 50.4 %

SAMPLE AREA = 10.8 M<sup>2</sup>

FREQ Hz	T20* empty	T20* sample	ABS COEFF a <sub>s</sub>	ASTM values
50	24.26	10.60	0.16	
63	21.84	7.19	0.27	
80	15.55	6.08	0.29	
100	13.35	4.62	0.41	
125	11.65	4.61	0.38	0.38
160	8.64	3.22	0.57	
200	10.50	3.88	0.48	
250	12.13	3.32	0.52	0.52
315	11.49	3.86	0.50	
400	9.03	2.72	0.46	
500	7.11	3.32	0.47	0.47
630	7.55	3.45	0.46	
800	7.76	3.78	0.40	
1000	7.90	4.00	0.36	0.36
1250	7.35	3.89	0.35	
1600	6.37	3.70	0.33	
2000	5.64	3.64	0.29	0.29
2500	4.99	3.29	0.30	
3150	3.90	2.83	0.28	
4000	3.02	2.35	0.28	0.28
5000	2.41	1.97	0.27	

\* Average of 12 decays

NRC (ASTM C423-90a) = .4

Tested by A. Wood Checked by [Signature]

Test Standard :- BS EN 20354:1993  
 Test Procedure :- 20354 issue 1  
 Program Name :- REV4B  
 Plot Program :- ABSPLOT2

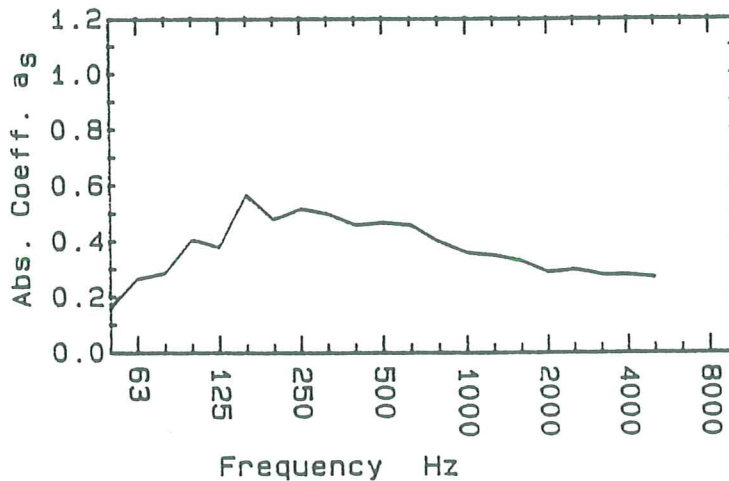



NAMAS  
TESTING  
N° 0296, 0296SI

The Building Test Centre  
British Gypsum Limited  
East Leake, Loughborough  
Leicestershire, LE12 6NP  
Tel. 0115 945 1564  
Fax. 01509 856780



## TEST METHOD AND CONDITIONS

The test room with a volume of 196m<sup>3</sup> is treated with 16 perspex diffusers of approximately 1220mm x 1220mm dimensions positioned randomly throughout the room.

The test specimen is of rectangular shape with an area between 10 and 12 m<sup>2</sup> placed in the test room so that no part of it is closer than 1m to any edge of the boundary of the room. The edges of the test specimen are tightly enclosed by a reflective frame, sealed to the floor and protruding above the surface of the test specimen.

The equivalent sound absorption area is determined by the measured reverberation times and used to calculate the absorption coefficients.

The repeatability of measurement for low absorption,  $r_1$ , and high absorption,  $r_2$ , are

Freq Hz	100	125	160	200	250	315	400	500	630	800	1000	1250	1600	2000	2500	3150
$r_1$	.035	.064	.018	.018	.035	0	.018	0	.035	.028	.028	.021	.053	.066	.033	.048
$r_2$	.056	.077	.085	.068	.146	.106	.213	.205	.2	.116	.051	.218	.109	.068	.048	.06

The figure below shows the section and floor plan view of the test room.

